

Warranty

Robotics Technologies, Inc. (RTI) warrants its products to be free from defects in materials and workmanship for a period of one (1) year from the date of purchase. Its obligation under this warranty is limited to repairing or replacing at its own sole option any such defective products. To obtain service under this warranty you must obtain a Return Material Authorization (RMA) number from RTI. Products must be returned to RTI with transportation charges prepaid and must be accompanied by a brief description of the problem encountered and proof of date and place of purchase. This warranty does not apply to equipment that has been damaged by accident, negligence or misapplication or has been altered or modified in any way. This warranty applies only to the original purchaser.

The Bus-Scan® Seat Check Reminder is not a security or detection device. It is used as a reminder for the driver to physically check seats.

It is the responsibility of the customer to ensure secure mounting and the continued maintenance thereof. Customer will indemnify RTI and hold it harmless from all actions or litigation arising from misuse of or improper mounting of the Bus-Scan®.

EXCEPT AS PROVIDED HEREIN RTI MAKES NO WARRANTIES, EXPRESS OR IMPLIED, INCLUDING WARRANTIES OF MERCHANTABILITY AND FITNESS FOR A PARTICULAR PURPOSE. Some states do not permit limitation or exclusion of implied warranties; therefore the aforesaid limitations(s) or exclusion(s) may not apply to purchaser.

EXCEPT AS PROVIDED ABOVE, IN NO EVENT WILL RTI BE LIABLE FOR DIRECT, INDIRECT, SPECIAL, INCIDENTAL, OR CONSEQUENTIAL DAMAGES ARISING OUT OF THE USE OF THIS PRODUCT EVEN IF ADVISED OF THE POSSIBILITY OF SUCH DAMAGE. Specifically, RTI is not liable for any costs such as loss of profits or revenue, loss of service, loss of equipment, costs of substitutes, and claims by third parties or otherwise. This warranty gives you specific legal rights and you may also have other rights that vary from state to state.

Bus-Scan BS 100

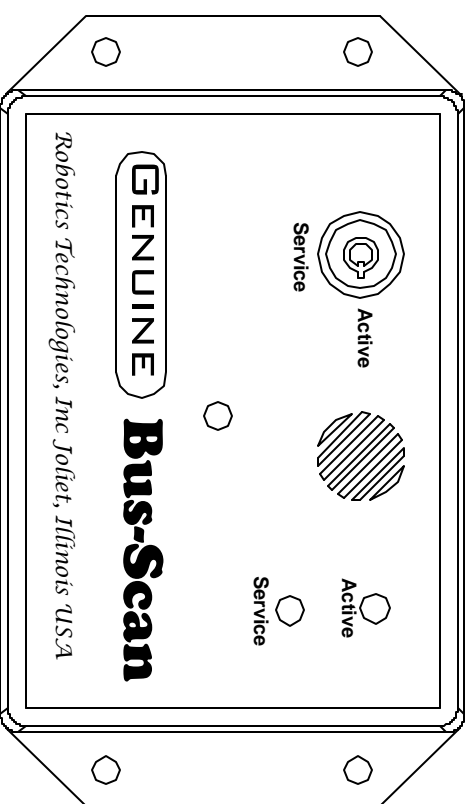

Installation Guide Operation Guide

RTI **ROBOTICS**
TECHNOLOGIES, INC

Joliet, IL Made in U.S.A

RTI **ROBOTICS**
TECHNOLOGIES, INC

Joliet, IL Made in U.S.A

www.roboticstech.com

Table of Contents

- 2 Return Policy and Contact Information
- 3 Supplied Components
- 4 BS 100 Features and Functions
- 5 BS 100 System Operation
- 6 Required Tool and Installation Instructions
- 7 Installation Instructions and System Testing
- 8 BS 100 Wiring Instructions
- 9 Trouble Shooting
- 10 RF Receiver / Transmitter
- 11 Specifications and Replacement Parts
- 12 Warranty

Return Policy

For Warranty Service, call Robotics Technologies, Inc. Customer Service to obtain an RMA (Return Materials Authorization), and then return the product postage prepaid to Robotics Technologies, Inc. The RMA number should be written clearly on the outside of the box. Please enclose a brief explanation of the problem, so that we can more efficiently diagnose your item and ensure timely service.

Contact Information

For support, please contact Robotics Technologies, Inc. or a Robotics Technologies Authorized Dealer.

Robotics Technologies, Inc.
20655 Burl Court
Joliet, IL 60433
Phone (800) 995-6056
Fax (815) 722-7655

Web sight: www.roboticstech.com

Specifications

BS 100 Control Unit

Dimensions: Length 5 1/2" Width 3 1/8" Height 2"
Enclosure Material: Flame Retardant ABS Plastic UL 94-5VA
Electrical System: 12v Negative Ground
Horn Activation: Form A Contact Fused @ 1 Amp
RF Receiver: 315 Mhz ASK

BS 100TX Remote Transmitter

Dimensions: Length 4 1/4" Width 2 3/8" Height 1"
Enclosure Material: Flame Retardant ABS Plastic UL 94-5VA
Battery: 12v Alkaline Battery MN21A GP23A or equivalent
Frequency: 315 Mhz ASK

Replacement Parts and Accessories

<u>Part No.</u>	<u>Description</u>
101881	BS 100 Control Unit
101549	BS 100TX Remote Transmitter
101624	12v Alkaline Battery
101071-K	Bus-Scan Service Switch Key
102894	BS 100 Parts Kit
102897	BS 100 Installation and Operations Guide
102893	Horn Relay Kit

RF Transmitter / Receiver

The BS100 is equipped with an RF transmitter and receiver. The signal is encoded with a digital code. The code of the transmitter must match the code of the receiver.

To Set the Code:

Transmitter:

- 1) Remove the 4 cover screws
- 2) Remove the cover
- 3) Set the dip switches to the desired code
- 4) Note the switch settings
- 5) Replace the cover
- 6) Replace the 4 cover screws

Receiver:

- 1) Remove the 4 mounting screws on the BS 100 unit
- 2) The dip switch is located on the back of the BS 100 unit
- 3) Match the code with the transmitter setting
- 4) Re-attach the BS 100 unit to the bus

Battery:

The BS100 remote transmitter is equipped with a 12v alkaline battery. The battery life is over 5 years in normal use; however, we recommend that the battery be replaced at the beginning of each school year.

To Replace the Battery:

- 1) Remove the 4 cover screws
- 2) Remove the cover
- 3) Replace the battery
- 4) Replace the cover
- 5) Replace the 4 cover screws

FCC ID: OF9-1229TXR1

This device complies with Part 15 of the FCC Rules. Operation is subject to the following two conditions: (1) This device may not cause harmful interference, and (2) This device must accept any interference received, including interference that may cause undesired operation.

Model No. BS100TX
 Robotics Technologies, Inc Joliet, IL
 Made in U.S.A.

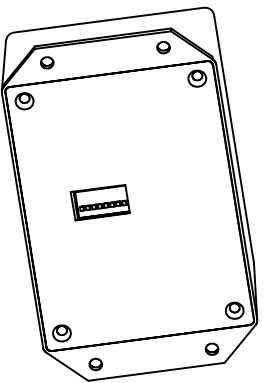
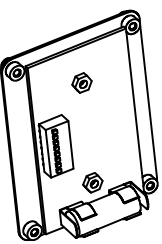
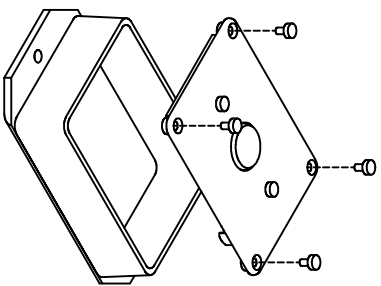

Supplied Components

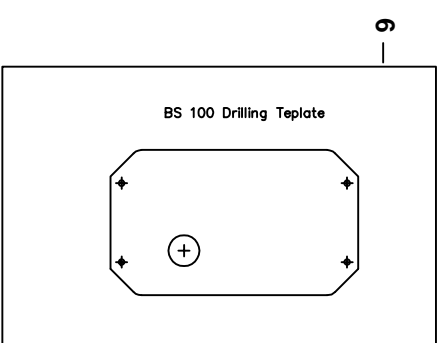
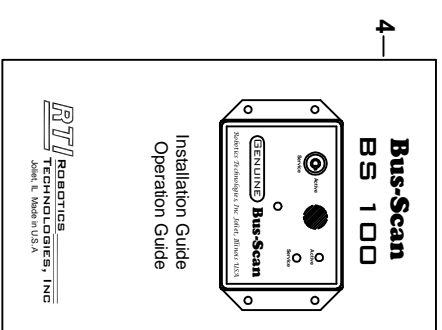
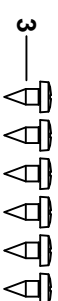
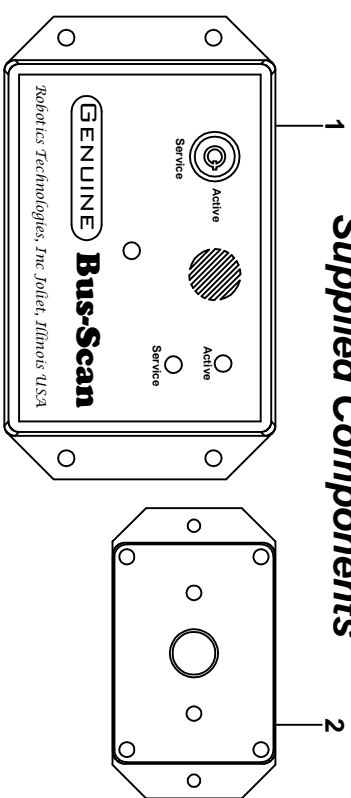

The following components are included with the BS 100

- 1 Control Unit (1)
- 2 Remote Transmitter (1)
- 3 # 8 x 3/8" sheet metal screws (6)
- 4 Bus-Scan Installation and operations guide (1)
- 5 Service override key (1)
- 6 Drilling template (1)

BS100 Features and Functions

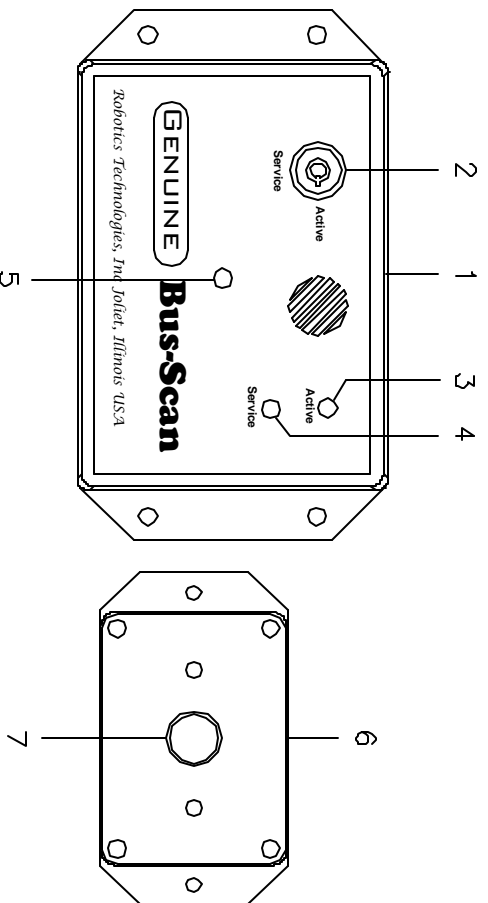

1 BS 100 Control Unit

The main control unit

2 Service Switch

Deactivates the BS 100. This feature is used when the vehicle is being serviced. The key removes only in the active position

3 Active indicator light

Lights when the system is armed

4 Service indicator light

Lights when the BS 100 is in the service mode

5 RF Link indicator light

Lights when the coded signal is received from the BS 100 Transmitter

6 BS 100TX Remote Transmitter

Transmits a digitally coded signal to the BS 100 Control Unit

7 Remote Transmitter Activation Button

Transmits when pushed

Trouble Shooting

No reminder tone or lights when Ignition is cycled

- 1 Check Red Wire for a constant +12V
- 2 Check Brown Wire
 - a) +12v when Ignition is on
 - b) 0v when ignition is off

Horn Sounds when ignition is turned off

- 1 Tamper Condition.
 - a) Remote Transmitter pushed during ignition cycling.

Reminder tone not sounding after a short ignition on/off cycle

- 1 Brown Out condition occurred during start up.
 - a) In order to eliminate any false triggering the **Bus-Scan** incorporates a power supply monitor. The supply voltage must be stable before the **Bus-Scan** examines the ignition voltage. This procedure takes 1-5 seconds depending on the status of the vehicles power system.
 - b) To test:
 - Keep the ignition on for 5 seconds before turning it off
 - c) If the vehicle has glow plugs:
 - Connect the Red wire to a different 12V supply source.

Remote Transmitter will not deactivate the system

- 1 Transmitter code does not match the receiver code.
- 2 Transmitter battery may need replacement.
- 3 Reorient the transmitter for a "clear path" to the receiver.

Alarm will not sound horn

- 1 Horn Switch Wire (Yellow) improperly wired.
- 2 Horn Switch Wire (Yellow) Fuse open.
- 3 Horn Ground Wire (Green) improperly wired.

Horn Switch Fuse Blows

- 1 Vehicle does not have a Horn Relay.
 - a) Install Horn Relay Kit Part No. 102893.
- 2 Horn Switch Wire (Yellow) improperly wired.

BS 100 Wiring Instructions

For a vehicle with a 12v negative ground electrical system and a Horn Relay Circuit. For vehicles without a horn relay a Horn Relay Kit Part No. 102893 is available.

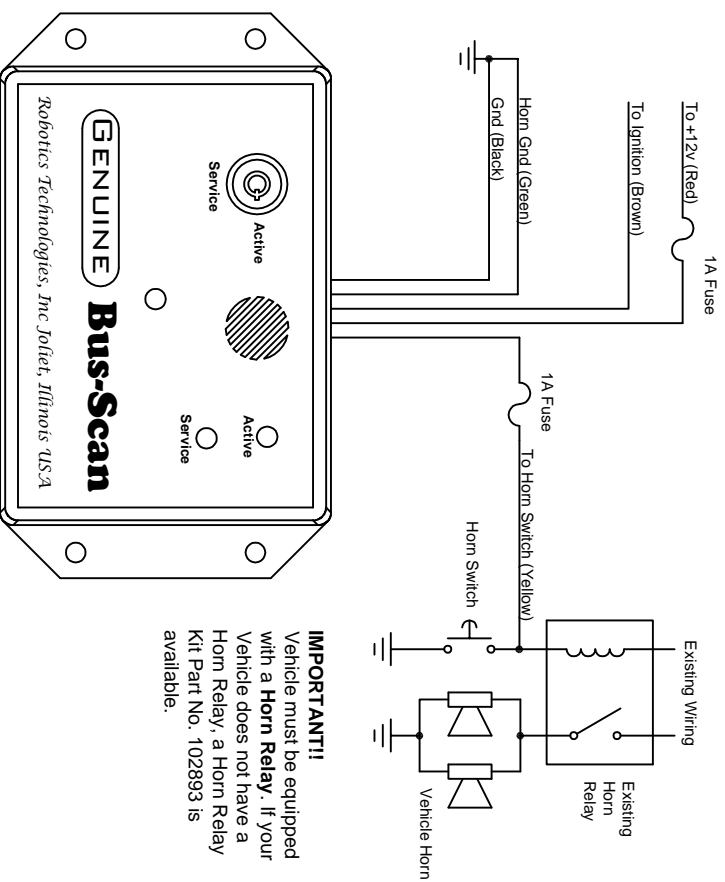

- 1) Connect the Red wire to a constant +12v.
- 2) Connect the Black wire to chassis ground.
- 3) Connect the Brown wire to the ignition circuit.
- 4) Connect the Green wire to chassis ground.
- 5) Connect the Yellow wire to the horn switch (button). The horn circuit must include a horn relay. If your vehicle does not contain a horn relay, a Horn Relay Kit Part No 102893 is available.

BS100 System Operation

The Bus-Scan BS100 system operates in the following sequence

- 1) The bus is started and the route begins.
- 2) After the route is completed and the bus is turned off, the BS100 emits a reminder tone.
- 3) The driver proceeds to the rear of the bus, checking for sleeping children.
- 4) The driver activates the remote transmitter.
- 5) The BS 100 is deactivated.
- 6) The driver exits the vehicle.

If the driver exits the vehicle without deactivating the BS 100, the horn will sound after 60 seconds. (Alarm Condition).

To Cancel the Alarm

- 1) The driver must cycle the Ignition off to on to off.
- 2) The driver must follow the proper deactivating sequence (steps 3-6 above)

The BS100 is equipped with a tamper feature that will alarm if the remote transmitter is tampered with.

A tamper condition exists if the remote transmitter is pushed during the cycling of the ignition from on to off.

To Cancel the Tamper Alarm

- 1) The Tamper condition must be removed
- 2) The driver must cycle the Ignition off to on to off
- 3) The driver must follow the proper deactivating sequence (steps 3-6 above)

Required Tools

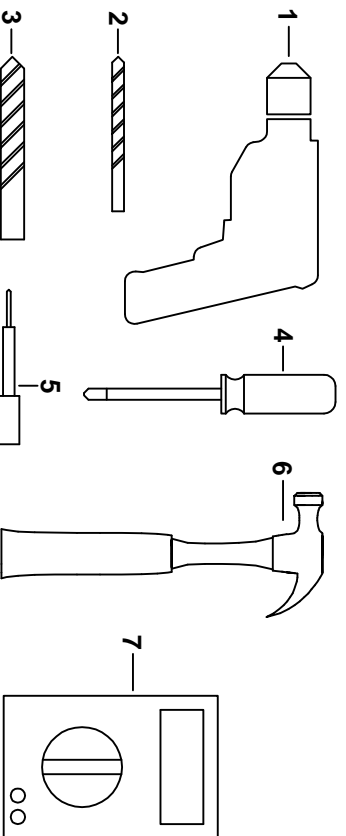

The following tools are required to install the BS 100

- 1 Electric drill
- 2 1/8" drill bit
- 3 1/16" drill bit
- 4 Phillips head screwdriver
- 5 Center punch
- 6 Hammer
- 7 Multi meter

BS 100 Components

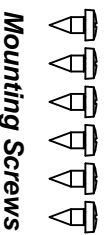
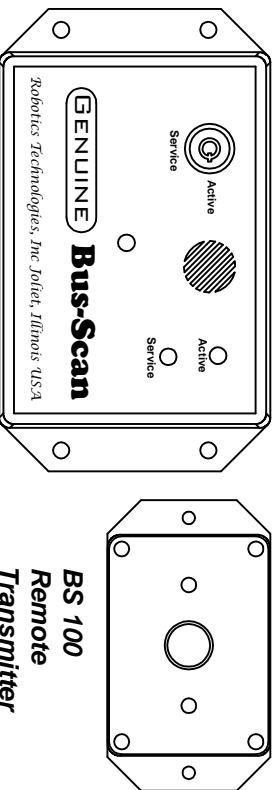

Mounting Screws

Installation Instructions

Mounting the BS 100

- 1 Locate a suitable location near the driver's compartment
- 2 Using the supplied Drilling Template center punch and drill according to the template
- 3 Wire the BS 100 according to the wiring instructions
- 4 Attach the BS 100 to the bus using 4 #8 x 3/8" sheet metal screws.

Mount the Remote Transmitter

- 1 Locate a suitable location where the Remote Transmitter may be mounted.
- 2 Center punch and drill the mounting holes
- 3 Attach the Remote Transmitter to the bus.

Test the Transmitter / Receiver

- 1 Activate the Remote Transmitter
- 2 Check the RF link indicator on the BS 100 Unit.
- 3 If the RF link indicator is not steady, reorient the transmitter for the strongest signal.

System Testing

Normal Test

- 1 Cycle Ignition off to on to off
 - a) Reminder tone on
 - b) Active LED on
- 2 Deactivate using Remote Transmitter
 - a) Reminder tone off
 - b) Active LED off System is now deactivated

Alarm Test

- 1 Cycle Ignition off to on to off
 - a) Reminder tone on
 - b) Active LED on
- 2 Wait for 60 Second Timeout
 - a) Horn Sounds
 - b) Recycle Ignition to cancel alarm

BS 100 Drilling Template

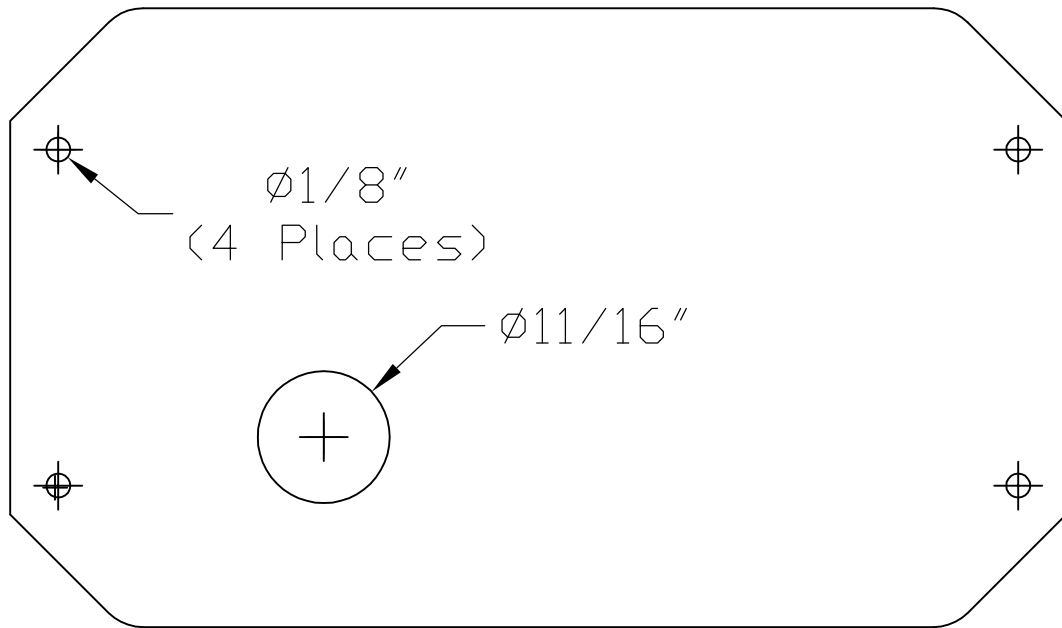

BS 100TX Drilling Template

