

DIGITAL 7100
1 Channel Mobile Digital Video Recorder

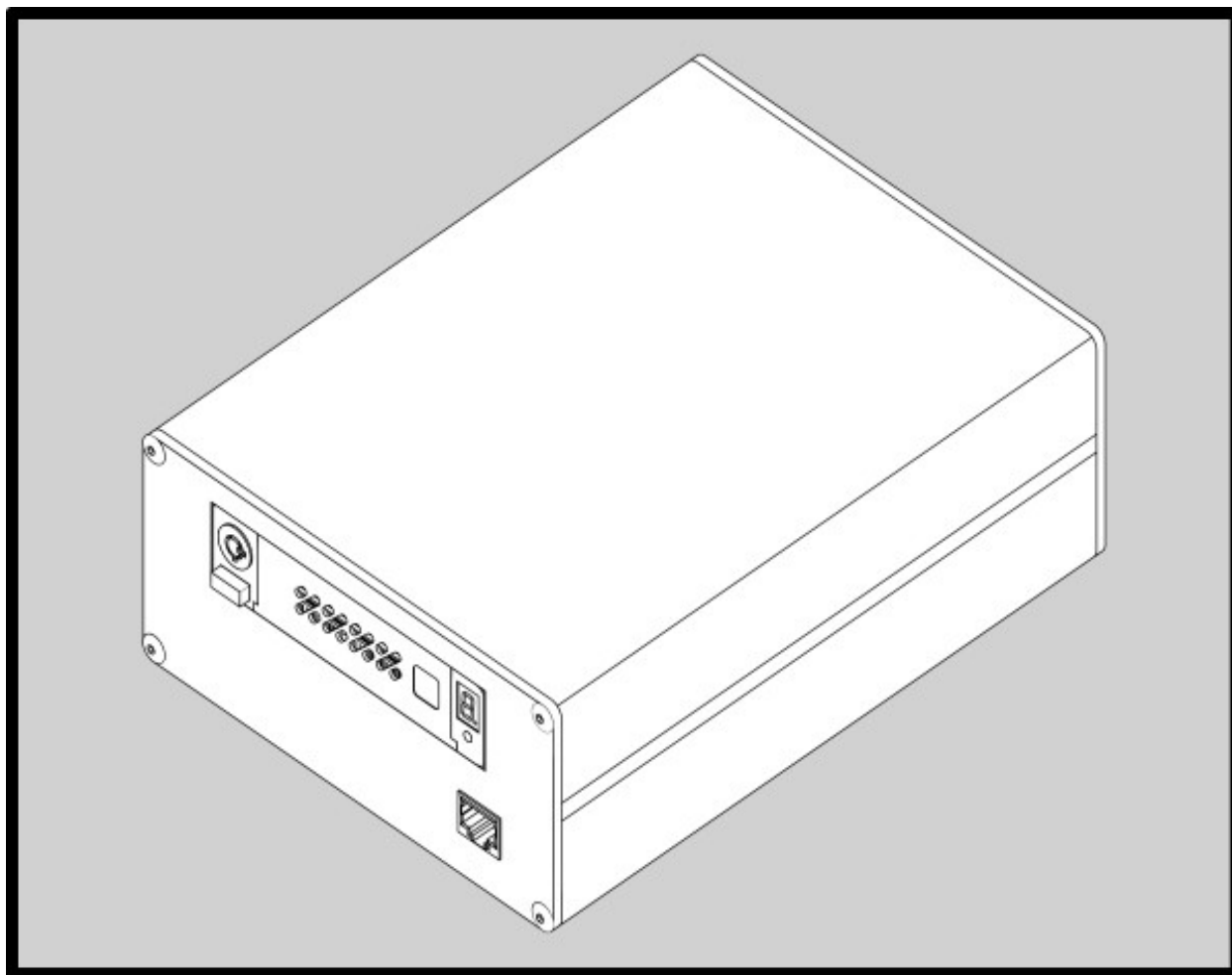

**Quick-Start
Instruction Manual**

RTI **ROBOTICS** **TECHNOLOGIES, INC.**
20655 BURL COURT JOLIET, IL 60433
VOICE: (815) 722-7650 FAX: (815) 722-7665

Unpacking the Digital 7100

Check for the following items in your package



Digital 7100



Remote Control w/Battery



10-24 square nuts (4)

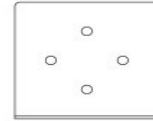

Mounting Brackets(2)



Signal Cable



Playback Cable



Power Cable



10-24 X 3/8 screws (4)

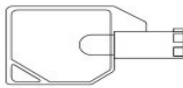

Hard Drive Key



Bookmark Switch Kit



#8 sheet metal screws(4)

If any of the items are missing, please contact RTI at **800-995-6056**

Note: The Removable Hard Drive is shipped installed and locked into the **Digital 7100 DVR**

Product Warranty

Robotics Technologies, Inc. (RTI) warrants this product to be free from defects in materials and workmanship for a period of one (1) year from the date of purchase. Its obligation under this warranty is limited to repairing or replacing at its own sole option any such defective products. To obtain service under this warranty, you must obtain a Return Material Authorization (RMA) number from RTI. Products must be returned to RTI with transportation charges prepaid and must be accompanied by a brief description of problem encountered and proof of date and place of purchase. This warranty does not apply to equipment that has been damaged by accident, negligence or misapplication, or has been altered or modified in any way. This warranty applies only to the original purchaser.

Except as provided herein, RTI makes no warranties, express or implied, including warranties of merchantability and fitness for a particular purpose. Some states do not permit limitation or exclusion of implied warranties; therefore, the aforesaid limitation(s) or exclusion(s) may not apply to the purchaser.

Except as provided above, in no event will RTI be liable for direct, indirect, special, incidental, or consequential damages arising out of the use of this product even if advised of the possibility of such damage. Specifically, RTI is not liable for any costs such as loss of profits or revenue, loss of equipment, costs of substitutes and claims by third parties or otherwise. This warranty gives you specific rights and you may also have other rights that vary from state to state.

Mounting the Digital 7100

1. Attach the 2 mounting brackets to the **Digital 7100** using the provided 10-24 screws and square nuts [Mounting brackets can be secured to the DVR in multiple orientations (see figures 1 and 2 for examples) to allow the DVR to be mounted almost anywhere].

Figure 1

Figure 2

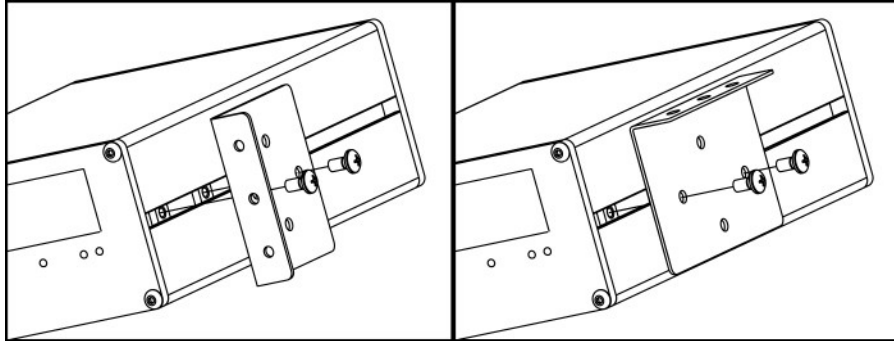

2. Secure the brackets to the desired location on the vehicle, using the provided #8 sheet metal screws [see figure 3. Note: Drill 1/8" pilot holes first].

Figure 3

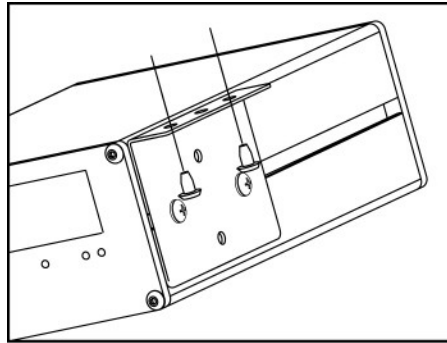

3. Drill a 11/16" mounting hole for **the bookmark switch** at desired location.

Wiring the Digital 7100

Note the rear-panel view of the **Digital 7100**:

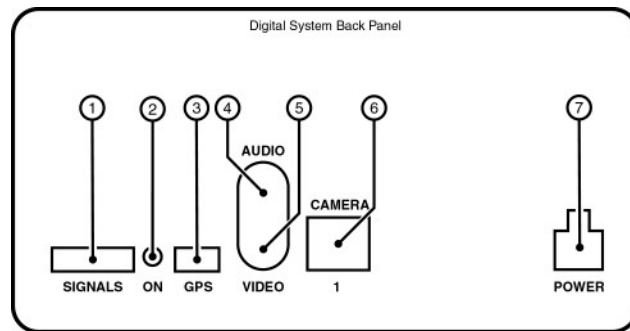

1. **Signal Connector** Provides on-screen display of vehicle activity (activation of Turn Signals, Brakes, etc. displays an on-screen icon) as well as Bookmark switch input. Used optionally (see wiring detail below).

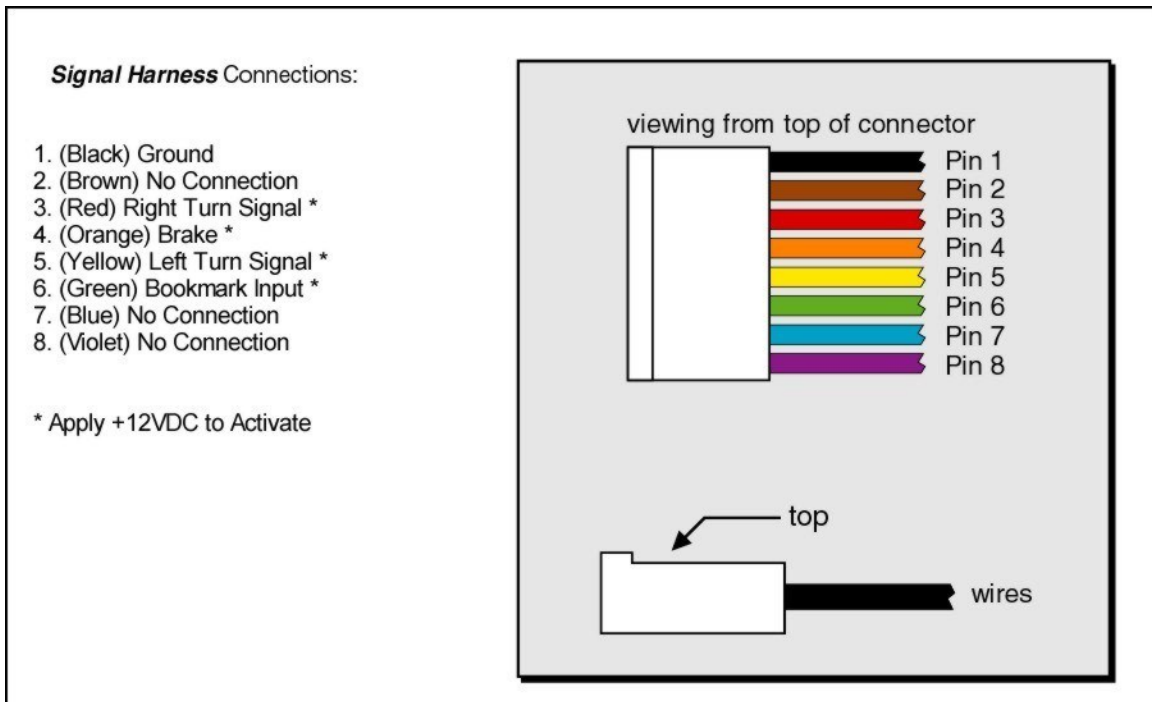

Wiring the Digital 7100 (Continued)

2. **Manual ON Switch** Used to power the **Digital 7100** manually, primarily for setup/programming.
3. **GPS Connector** Input for optional **RTI GPS** (Global Positioning System) module.
4. **Audio-Out RCA (Phono) Jack** provides audio signal to monitor or TV. Primarily for setup/programming, and not used during normal operation.
5. **Video-Out RCA (Phono) Jack** provides video signal to monitor or TV. Primarily for setup/programming, and not used during normal operation.
6. **Camera Input** Accepts standard RTI Plug-and-play Video Camera with integral microphone.
7. **Power Connector** Power, ground and Ignition connections (see wiring detail below).

Black
Blue
Red

Ground
Ignition -- Direct from Ignition switch
+12 to 24 VDC -- From the most stable, direct source

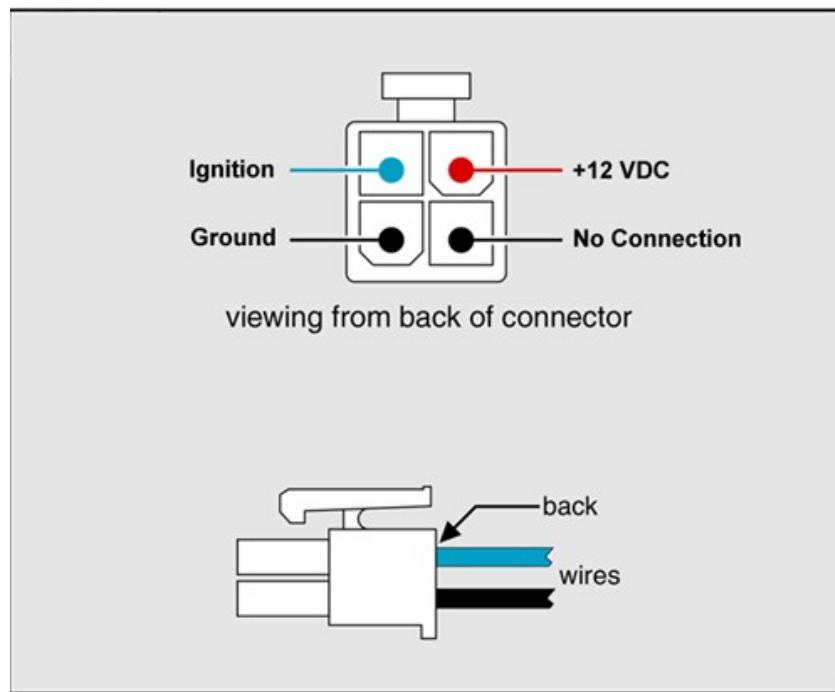

Important Note:

Although the Digital 7100 has excellent power-conditioning and noise suppression circuitry, all electronic equipment is susceptible to extreme interferences that can be present in vehicle electrical systems. Accessories that include motors, transformers and solenoids can introduce voltage spikes reaching thousands of volts, and the user should ensure that all critical devices (including the Digital 7100) are protected with sufficient power conditioning as required.

Digital 7100 Initial Setup

Once the mounting and wiring have been completed, the final step is to setup the operating parameters for the **Digital 7100**. Before undertaking the following instructions, it is assumed that the **RTI** camera has been installed according to its provided instructions.

IMPORTANT!

Before starting this setup, make sure that you have properly installed the removable hard drive and locked it into the Digital 7100. The Digital 7100 will not operate properly unless this has been done. The “locked” state is indicated by a lighted red LED on the front of the Hard Drive.

1. Connect a suitable video monitor or TV with A/V jacks to the **Digital 7100** Audio and Video jacks located on the rear panel of the unit. (See earlier wiring instructions). Make sure that the Video Out of the DVR is connected to the Video In of the monitor/TV, and that the Audio Out of the DVR is connected to the Audio In of the monitor/TV.
2. Press the **Manual Power** switch located on the rear panel of the **Digital 7100** to power the unit.
3. After a few moments, the monitor/TV should display a live picture of the video camera view, as well as start-up diagnostic messages.
4. When the **Digital 7100** has finished its start-up sequence, make sure that it is not in **RECORD** mode (indicated by the display of **AR** or **MR** in the lower-right corner of the screen) before attempting to program the unit. If the unit is in **RECORD** mode, then aim the provided remote control at the front panel of the unit and press **STOP**.
5. Press **MENU** to enter the programming mode. The first task is to initialize the **Digital 7100** to factory defaults. This ensures that you are starting with a “clean slate”. To do so, select **System Program Menu**, then select **System Defaults**. When confirmation is requested, press “**Yes**”.
6. Once the system has been initialized, then you can navigate through the menus to configure the **Digital 7100** to your requirements. See the following pages for a comprehensive listing of the menu structures.

Digital 7100 Live Menu Structure

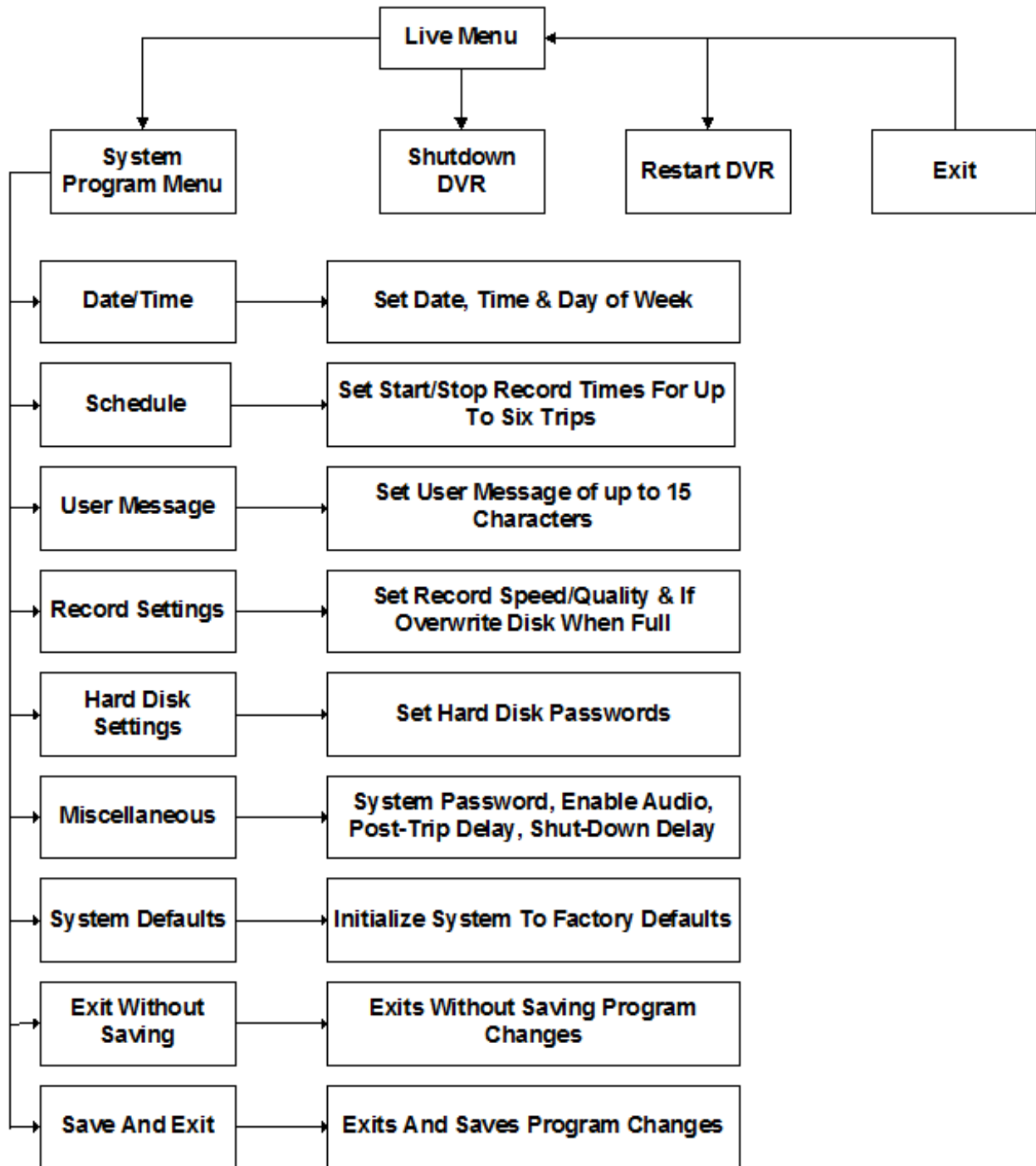

Digital 7100 Playback Menu Structure

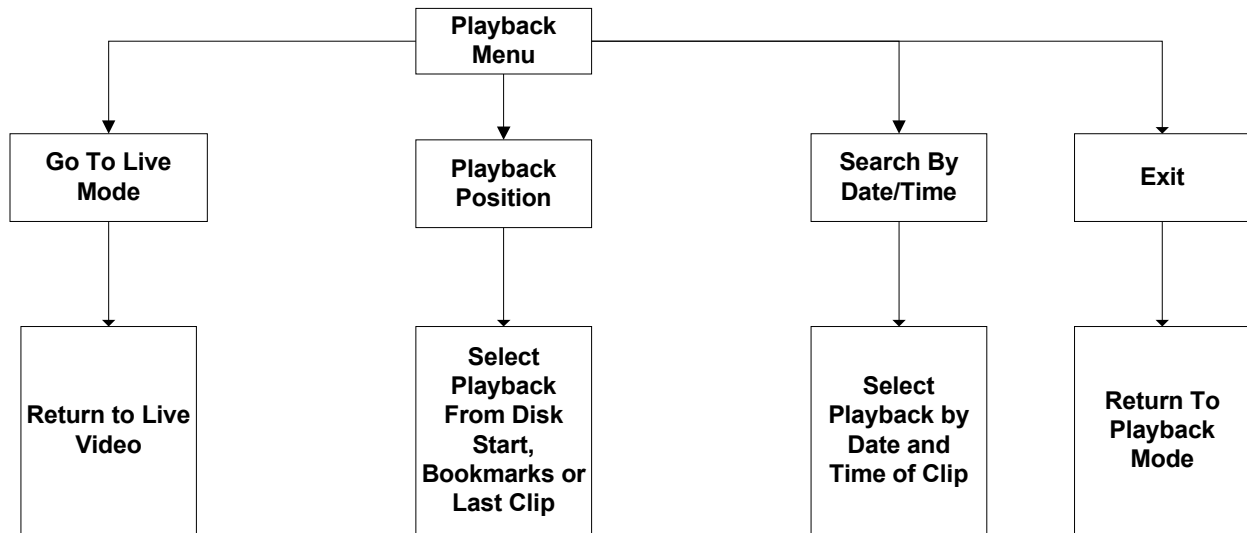

Notes On Menus

1. Using **ESC** to leave any menu will not save any changes you made to that menu. You must select Back and press **ENTR** to leave any menu that you made changes to. Also note that when all your programming is done you **MUST** select 10. Save and Exit in order for those changes to be saved.
2. Note that all values shown (except Date and Time) are the system default settings.
3. Use **▲** and **▼** on remote to select menu items and to change value of items.
4. Use **ENTR** button on remote to choose menu item and to advance to next variable when programming.

Digital 7100 Quick Tips

Q: How do I set the Date and Time?

A:

1. Press **Menu** on the remote control.
2. Select **System Program Menu**.
3. Select **Date/Time**.
4. Use the **UP** and **DOWN** keys to change the Date and Time values.
5. Select **SET TIME** and press **ENTR**.
6. Press **ESC** to exit.

Q: Can I disable the recording of sound?

A: Yes. Pressing the **MUTE** button on the remote control will disable sound recording. This is a toggle (alternating) function, so pressing **MUTE** again will restore the recording of sound. This setting is stored in memory and controls system sound recording until changed.

Q: What is a Bookmark, and how do I use it?

A: A Bookmark allows a driver to place an electronic marker on the recording so that a incident can be easily navigated to and reviewed at a later time. This saves valuable time when you are managing and organizing the recorded clips. The Bookmark switch can be conveniently located near the driver. Bookmarked incidents may be easily found and reviewed as follows:

1. Press **PLAY** on the remote control to enter Playback Mode.
2. Press **MENU** to enter the Playback Menu.
3. Choose **Play From Next** or **Prev Bookmark** to review the clip.
4. Press **ESC** to exit when you are finished.

These stored bookmarks may also be used in the provided RTI software for review on your computer. See the software manuals for complete instructions.

Q: What is a Post-Trip Delay, and how do I use it?

A: This feature allows the continuation of recording for a set period of time after the ignition has been turned off. This is valuable for the continued recording of activity during passenger disembarkation. The duration of this delay can be set as follows:

1. Press **MENU** on the remote control.
2. Select **System Program Menu**.
3. Select **Miscellaneous**.
4. Select **Shutdown Settings**.
5. Select the **Post Trip Delay** setting.
6. Use the **UP** and **DOWN** remote keys to set the duration in minutes.
7. Press **ESC** to return to the **Miscellaneous** Menu.
8. Press **ESC** to return to the **System Program Menu**.
9. Select **Save and Exit**.

Digital 7100 Quick Tips (Continued)

Q: How Do I Schedule a Trip?

A: Up to six programmed start and stop recording times (Trips) may be scheduled.

1. Press **MENU** on the remote control.
2. Select **System Program** Menu.
3. Select **Schedule** Menu.
4. Select the desired **Start** and **Stop** times and set their values with the **UP** and **DOWN** keys. Repeat this step for up to six trips.
5. To disable any trip, set its **Start** and **Stop** times to equal time values, or to zero.
6. Select **Schedule ON** to activate the scheduling function. **All trips may be enabled or disabled globally without disturbing the trip settings by using this setting.**
7. Select **BACK** to return to the **System Program** menu.
8. Select **Save and Exit**.

Q: How Can I View My Recorded Clips?

A: There are two ways to view your recorded clips:

1. With a video monitor/TV connected to the A/V (Phono) Jacks located on the rear panel of the **Digital 7100**. This is the least practical method for normal operational use.
2. By unlocking and removing the hard drive, then plugging into the **RTI** docking station. The docking station connects to the USB 2.0 port of a computer, and uses the **RTI** program "**RTIDiskView**" to view and save clips.

Complete instructions for the docking station are detailed in the **RTI Digital Video Software Manual**. **RTI Digital Video Systems** create very high quality, advanced technology digital video. Ensure that your viewing computer meets the following minimum standards:

Minimum System Requirements

| | |
|-----------------------|---|
| CPU | Intel Pentium 4 or equivalent @ 1 GHZ Minimum |
| Video Card | ATI Radeon 7500 / NVIDIA GeForce2 / Intel i865 / SIS Sabre, etc. |
| Operating System | Windows XP Professional or Vista |
| DirectX | 8 |
| Screen Resolution | 1024 x 768 |
| Installed Video Codec | DivX Decoder 8.0 or higher (Free download from www.divx.com) |
| Free HDD Space | 2 to 4 GB for video clip storage |
| Memory (DRAM) | 256 MB |